

**MEDI-KOOL™  
RX CLIMATE CONTROL UNITS  
INSTALLATION INSTRUCTIONS  
AND OWNER'S MANUAL**



**FMMS**

**FREEDOM MEDICAL &  
MARINE SOLUTIONS**



**2651 PARK WINDSOR DR  
SUITE 203, FORT MYERS  
FL 33901  
(239)-689-5033  
OFFICE@FMMSUSA.COM**

**DBA MERMAID  
MANUFACTURING**



# TABLE OF CONTENTS

WARRANTY	2
INSTALLATION AND VENTING	3
WIRING	4
SETTING PARAMETERS FOR MEDI-KOOL CONTROL BOARD	5
OPERATION AND MAINTENANCE	6
TROUBLESHOOTING	7-8
WIRING SCHEMATIC 2020-CURRENT	9
MASTERFLUX CASCADE COMPRESSOR (09/2015-2020)	10
DANFOSS BD35/BD50 INFORMATION (PRE 09/2015)	11
THANK YOU!	12

## IMPORTANT UPDATE FOR FREEDOM MEDICAL AND MARINE SOLUTIONS:

**ANY INFORMATION IN THIS BOOKLET REGARDING  
THE MASTERFLUX CASCADE COMPRESSOR  
APPLIES TO UNITS BUILT BETWEEN 09/2015  
AND 2020. FOR ANY QUESTIONS  
REGARDING THIS UPDATE PLEASE CALL OR EMAIL  
TECH SUPPORT.**

# WARRANTY INFORMATION

SHOULD YOUR MEDI-KOOL PRODUCT FAIL TO FUNCTION (DUE TO A DEFECT IN MATERIAL OR WORKMANSHIP) WITHIN 5 YEARS FROM THE DATE OF MANUFACTURING, **FREEDOM MEDICAL AND MARINE SOLUTIONS** (HEREAFTER **"FMMS"**) WILL REPLACE OR REPAIR (AT FREEDOM'S DISCRETION) ANY DEFECTIVE PARTS FREE OF CHARGE AFTER WRITTEN NOTICE TO FMMS OF YOUR INTENT TO SHIP THE PRODUCT BACK TO OUR FACTORY WITH TRANSPORTATION CHARGES PRE-PAID. ALL UNITS ARE SHIPPED AND SENT VIA LTL FREIGHT, IN A BOX ON A PALLET FOR SAFE KEEPING. WE WILL NOT ACCEPT ANY REPAIR UNITS VIA "GROUND" SHIPPING. FMMS AGREES TO PAY FREIGHT SHIPPING TO AND FROM THE CUSTOMER WITHIN THE FIRST YEAR. AFTER THE FIRST YEAR, FMMS WILL NOT BE RESPONSIBLE FOR SHIPPING, BUT WILL STILL SERVICE THE UNIT FREE OF CHARGE UP TO 5 YEARS, AS LONG AS IT'S DEEMED A MANUFACTURER DEFECT. AFTER 5 YEARS, LABOR CHARGES OF \$100 PER HOUR WILL BE APPLICABLE ALONG WITH PARTS COST. THIS ALSO APPLIES IF IT IS NOT A MANUFACTURER DEFECT.

FMMS IS NOT RESPONSIBLE FOR THE INSTALLATION OR DE-INSTALLATION OF THE UNIT. FMMS IS NOT RESPONSIBLE FOR LABOR REIMBURSEMENT.

## ALL PURCHASED CLIMATE CONTROL CABINETS ARE NON-REFUNDABLE AND NON-RETURNABLE

CONTROL BOARDS ARE COVERED FOR ONE YEAR. WE DO HAVE THE ABILITY TO REPAIR CERTAIN CONTROL BOARDS. AFTER OUR STANDARD ONE YEAR, IF THE CONTROL BOARD FAILS, THERE IS A \$100 CHARGE FOR CONTROL BOARD REPAIRS. TECUMSEH COMPRESSORS ARE COVERED FOR ONE YEAR. THE ONE YEAR PROVISION OF THIS LIMITED WARRANTY SHALL BE VOID IF EITHER THE CIRCUIT BOARD OR ANY MAJOR COMPONENT HAS BEEN DAMAGED AFTER THE SALE, SUBJECTED TO UNREASONABLE OR ABNORMAL USE OR OPERATION, ALTERED, REPAIRED BY ANYONE OTHER THAN FMMS WITHOUT THE COMPANY'S CONSENT, WIRED WITH UNDERSIZED WIRE (CONSULT FACTORY FOR QUESTIONS AND/OR SEE "WIRING INSTRUCTIONS" AS LAID OUT IN THIS GUIDE, OR INSTALLED OR USED OTHER THAN AS INDICATED IN THIS INSTALLATION AND USER'S GUIDE.

## LIMITATION OF LIABILITY:

FMMS IS DEDICATED TO MANUFACTURING QUALITY MARINE AND MEDICAL RELATED PRODUCTS. IN NO EVENT SHALL FMMS BE LIABLE FOR ANY INDIRECT, INCIDENTAL OR CONSEQUENTIAL DAMAGES ARISING OUT OF ANY SALE OR OPERATION OF THE PRODUCTS SOLD AND/OR INSTALLED. THE PURCHASER OF THE USER WILL HOLD FMMS HARMLESS OF ANY INCIDENT CAUSED BY THE FAILURE OF THE FMMS PRODUCT UP TO AND INCLUDING INJURY OR DEATH. AND IN NO EVENT SHALL FMMS'S OBLIGATION EXCEED THE VALUE OF THE PRODUCT(S) SOLD.

## INSTALLATION

- 1.) BASED ON YOUR MK MODEL'S DIMENSIONS, PLEASE DETERMINE YOUR "CUT OUT" DIMENSIONS FOR YOUR CABINET. PLEASE BE SURE TO INCLUDE ENOUGH SPACE FOR THE COMPRESSOR.  
COMPRESSOR LEFT, RIGHT, REAR: 13" WIDE X 7" DEEP X 7.5" HIGH  
COMPRESSOR TOP: 13" WIDE X 7" DEEP X 8.5" HIGH
- 2.) DETERMINE HOW YOU WILL SUPPLY POWER TO THE LOCATION
- 3.) BASED ON THE COMPRESSOR, FIND A LOCATION FOR A "VENT" TO ALLOW AIRFLOW THE COMPRESSOR. (SEE "VENTING" BELOW)  
**THIS IS A CRITICAL REQUIREMENT!**
- 4.) HOW WILL THE UNIT BE MOUNTED? EACH UNIT COMES WITH A 1.25" FLANGE AROUND THE CABINET FOR PROPER MOUNTING. ENSURE THE LOCATION IS STRONG ENOUGH TO ACCOMODATE THE WEIGHT OF THE UNIT. (IF NEEDED, PLEASE INSTALL A SUPPORT BLOCK UNDER THE BODY OF THE UNIT. THIS WILL ALLEVIATE PRESSURE ON THE FLANGE)
- 5.) CHOOSE A LOCATION FOR THE MEDI-KOOL TEMPERATURE CONTROL PANEL. EACH UNIT IS PRE-WIRED WITH 5' OF CABLE AND PROTECTED USING A 10 AMP FUSE. IT IS IMPORTANT NOT TO DAMAGE THE CONTROL PANEL OR DISTURB THE WIRING ON THE REAR OF THE UNIT. IF A LONGER CABLE IS NEEDED, PLEASE CONTACT FREEDOM IMMEDIATELY. **DO NOT SPLICE THE WIRES IN ANY SITUATION!**

**FAILURE TO FOLLOW THESE INSTRUCTIONS WILL VOID ALL WARRANTIES ON THE PRODUCT**

## VENTING

**VENTING YOUR MEDI-KOOL UNIT IS EXTREMELY IMPORTANT. THE COMPRESSOR NEEDS PROPER AIRFLOW IN ORDER TO MAINTAIN OPERATION. WITHOUT AIRFLOW THE COMPRESSOR WILL OVERHEAT, CAUSING UNIT FAILURE**

- 1.) PROPER VENTILATION IS REQUIRED FOR COMPRESSOR AND UNIT OPERATION. VENTILATION AIR CAN COME FROM EITHER THE PATIENT COMPARTMENT OR OUTSIDE. OUTSIDE VENTILATION IS ALWAYS PREFERRED.
- 2.) BOTH AN INTAKE AND EXHAUST VENT IS REQUIRED. DUE TO HIGH TEMPERATURES IN MANY AREAS OUR UNITS ARE OPERATED IN, 100 CFM OF VENTILATION AIRFLOW IS RECOMMENDED USING AN EXTERNAL VENT FAN. VENT FAN CANNOT BE TIED TO UNIT'S POWER.
- 3.) SHOULD YOU EXPERIENCE THE SYSTEM NOT OPERATING PROPERLY, VERIFY THE VENTING AREA IS NOT OBSTRUCTED AND THE AUXILIARY FAN HAS NOT STOPPED PERFORMING.

**FAILURE TO VENT THE UNIT PROPERLY VOIDS ALL WARRANTIES!**

## WIRING

- 1.) HARD WIRE THE MEDI-KOOL ELECTRICAL CONNECTION TO THE 12-VOLT DC POWER SOURCE ON THE VEHICLE. THE BACK OF EACH UNIT WILL HAVE A (+) AND A (-) LABEL INDICATING WHERE THE POWER FOR THE VEHICLE IS TO BE PLACED. THEY WILL BE NEAR THE WHITE TERMINAL BLOCK. IF POSSIBLE, USE COPPER CONDUCTORS WITH A MINIMUM OF #14 AWG WIRE. THE LONGER THE WIRE LENGTH FROM THE POWER SOURCE TO THE UNIT, THICKER GAUGE WIRE IS NEEDED. **IT IS RECOMMENDED NOT TO EXCEED 15' OF WIRE. IF A LONGER DISTANCE IS REQUIRED, ENSURE THE GAUGE OF 12-VOLT DC WIRE HAS BEEN UPGRADED**
- 2.) DUAL TEMP UNITS REQUIRE A SEPARATE POWER SUPPLY FOR EACH COMPRESSOR UNIT. YOU CANNOT RUN A DUAL UNIT ON ONE POWER SUPPLY, THIS WILL RESULT IN FAILURE.
- 3.) A **CONSTANT** 12-VOLT DC POWER SUPPLY IS RECOMMENDED TO ENSURE UNINTERRUPTED OPERATION OF THE MEDI-KOOL UNITS. IF A BATTERY ISOLATOR IS REQUIRED, ENSURE THE OPERATOR UNDERSTANDS PROGRAMMING THE MEDI-KOOL CONTROL BOARD MAY BE REQUIRED ON RE-START.
- 4.) THE DIGITAL CONTROL BOARD HAS QUICK CONNECT FITTINGS FOR EASE OF INSTALLATION. SHOULD THE WIRES NEED TO BE REMOVED FOR INSTALLATION, ENSURE THE PROPER LEADS ARE REPLACED IN THEIR RESPECTIVE POINTS. **FAILURE TO RE-CONNECT THE WIRES PROPERLY WILL RESULT IN AN OPERATIONAL FAILURE OF THE COMPRESSOR.**
- 5.) THE THERMOSTAT CABLE **IS NOT** LOCATED IN THE QUICK CONNECT FITTINGS. IT IS THE RESPONSIBILITY OF THE INSTALLER TO CONNECT THE THERMOSTAT LEADS TO THE CONTROL BOARD ONCE THE UNIT HAS BEEN INSTALLED. SEE "SETTING PARAMETERS FOR THE CONTROL BOARD" FOR MORE INFORMATION.

**DO NOT CUT OR SPLICE THE THERMOSTAT CABLE OR THE PRE-MADE WIRING HARNESS. FAILURE TO FOLLOW THIS INSTRUCTION WILL VOID ALL WARRANTIES**

## SETTING PARAMETERS FOR CONTROL BOARD

FMMS HAS 3 TYPES OF CONTROL BOARDS IN OPERATION:

- 1ST TYPE:** STAINLESS STEEL PLATE WITH A DISPLAY AND A TURN KNOB IN THE MIDDLE. THIS IS THE ORIGINAL CONTROL BOARD WITH A 3 WIRE THERMOSTAT ENDING IN A PLUG THAT CONNECTS TO THE BACK OF THE CONTROL BOARD. IT WILL HAVE A SERIAL NUMBER BELOW 8000
- 2ND TYPE:** IDENTICAL TO THE 1ST TYPE. THE SERIAL NUMBER WILL BE ABOVE 8000 AND IT WILL HAVE A 3 MINUTE DELAY SET TO RUN WITH THE CASCADE COMPRESSOR USED BETWEEN 09/2015 AND 2020,
- 3RD TYPE:** STAINLESS STEEL PLATE WITH AN INKBIRD BRANDED BOARD. THIS BOARD WILL BE GREY WITH A RED DIGITAL DISPLAY. SOME PARAMETERS ON THIS BOARD MAY NEED TO BE SET UP FOR YOUR SPECIFIC APPLICATION.

### PROGRAMMING THE INKBIRD CONTROL BOARD

- 1.) TO SET UP THE BOARD, PRESS AND HOLD THE BUTTON WITH THE "S" UNTIL LETTERS SHOW ON THE DISPLAY. PRESS UP OR DOWN TO VIEW THE DIFFERENT PARAMETERS, PRESS "S" TO VIEW THE NUMBER VALUE, PRESS UP OR DOWN TO CHANGE THE VALUE, PRESS "S" TO SAVE THE SETTING
- 2.) "TS" IS THE TEMPERATURE SETPOINT, AND CAN BE SET FOR HEATING OR COOLING.
- 3.) "DS" IS THE TEMPERATURE DIFFERENTIAL. THE CABINET WILL SIT UNTIL THE TEMPERATURE IS THE DIFFERENTIAL VALUE AWAY FROM THE SETPOINT. E.G. :IF THE SETPOINT IS 40 DEGREES AND THE DIFFERENTIAL IS SET TO 3 THE CABINET WILL NOT COOL UNTIL THE TEMPERATURE IN THE CABINET REACHES 43 DEGREES.
- 4.) "PT" IS THE COMPRESSOR DELAY BETWEEN CYCLES (IN MINUTES)
- 5.) "CA" IS THE TEMPERATURE CALIBRATION, OR OFFSET. THIS SHOULD BE SET TO ZERO
- 6.) "CF" IS CELSIUS OR FAHRENHEIT TEMPERATURE DISPLAY. SET THIS TO PREFERENCE
- 7.) TEMPERATURE SENSOR IS BLACK WIRE THAT COMES OUT OF THE BACK OF THE UNIT AND PLUGS INTO TERMINALS 3 AND 4 ON THE CONTROL BOARD. DOES NOT MATTER WHICH TERMINAL EACH WIRE GOES TO, THERE IS NO (+) OR (-)

**WARRANTY: ALL CONTROL BOARDS HAVE 1-YEAR WARRANTY**  
**WE CAN REPAIR THE 1ST AND SECOND TYPE OF CONTROL BOARD,**  
**THE 3RD TYPE IS REPLACEMENT ONLY**

# **OPERATION AND MAINTENANCE**

**TURN THE UNIT ON AND LET IT RUN FOR SEVERAL HOURS PRIOR TO FILLING THE UNIT WITH ITS CONTENTS**

**DO NOT RUN THE UNIT WITH THE DOOR OPEN FOR AN EXTENDED PERIOD OF TIME. THIS WILL ONLY INCREASE THE FROST ON THE EVAPORATOR, INCREASE PRODUCT TEMPERATURE, AND REDUCE THE EFFICIENCY OF THE UNIT.**

**YOUR MEDI-KOOL UNIT AUTOMATICALLY MONITORS THE INCOMING VOLTAGE AND WILL CYCLE THE COMPRESSOR OFF IF THE INCOMING VOLTAGE DROPS BELOW THE RECOMMENDED MINIMUM OF 9.7 VOLTS. THIS FEATURE IS DESIGNED TO MAKE SURE YOUR BATTERIES WILL STILL BE STRONG ENOUGH TO START THE VEHICLE.**

**AS WITH ANY OTHER 12-VOLT LOAD APPLIED TO AN IDLE BATTERY, THE BATTERY POWER WILL EVENTUALLY BEGIN TO RUN DOWN. SOME FORM OF RECHARGING THE BATTERY IS NECESSARY FOR CONTINUOUS OPERATION OF THE UNIT OVER EXTENDED OPERATING PERIODS. HOW LONG THE BATTERY, OR BATTERIES, WILL LAST ON A SINGLE CHARGE WILL DEPEND ON THE OPERATING TIME OF THE UNIT AND THE DESIRED SET TEMPERATURE. FACTORS THAT DETERMINE OPERATING TIME INCLUDE: LOAD ON THE UNIT, AMBIENT TEMPERATURE, SET TEMPERATURE, AND USE (DOOR OPENING AND CLOSING) OF THE UNIT. A KEY NOTE TO REMEMBER IS MORE CYCLES THE COMPRESSOR HAS TO TAKE TO ACHIEVE THE ITS DESIRED SET TEMPERATURE= MORE BATTERY LIFE. CONTINUOUS OPERATION OF THE UNIT AS A RESULT OF ANY OF THE ABOVE= SHORTER BATTERY LIFE.**

## **CLEANING THE MEDI-KOOL UNITS**

**IT IS IMPORTANT TO KEEP THE INTERIOR OF THE UNIT CLEAN AND MOISTURE FREE TO AVOID ANY MOLD OR MILDEW GROWTH.**

**USE A MILD DETERGENT (DISH SOAP) AND WARM WATER TO PERIODICALLY WIPE OUT THE INTERIOR OF THE UNIT. ENSURE THE DOOR GASKET IS CLEANED AND INTACT. MAKE SURE THE UNIT IS DRY BEFORE OPERATION IS RESUMED. THE USE OF "WD-40" OR "SHEILA SHINE" IS RECOMMENDED TO KEEP THE STAINLESS STEEL UNITS CLEAN.**

**NOTE: DO NOT USE ANY ABRASIVE CLEANERS, CHEMICALS, OR SCOURING PADS AS THIS MAY DAMAGE YOUR UNIT AND TRANSFER CHEMICALS TO THE CONTENTS**

**THANK YOU AGAIN FOR PURCHASING THE MEDI-KOOL VEHICLE CLIMATE CONTROL SYSTEM. THE INFORMATION PROVIDED IS MEANT TO ASSIST YOU DURING YOUR INSTALLATION AND MAINTENANCE OF THE UNIT. SHOULD NEED ANY ADDITIONAL ASSISTANCE, PLEASE DON'T HESITATE TO CONTACT US!**

## TROUBLESHOOTING

THE COMPRESSOR OPERATES THE SPECIFIC CLIMATE CONTROLLED CABINET VIA AN ELECTRONIC MODULE THAT IS CONNECTED TO THE SIDE OF THE COMPRESSOR.

HERE, AT THE MODULE, IS WHERE ALL THE WIRING IS CONNECTED IN ORDER TO OPERATE THE CONDENSER FAN, THE COMPRESSOR, AND THE CIRCUIT CONTROL BOARD. SHOULD THE UNIT NOT FUNCTION, PLEASE REFER TO THIS SECTION FOR ASSISTANCE. SHOULD ANY ADDITIONAL INFORMATION BE NEEDED, CONTACT THE FMMS FACTORY.

### **COMPRESSOR OPERATES, NO COOLING:**

- 1.) CHECK THAT THE CONDENSER FAN, LOCATED ABOVE THE COMPRESSOR, IS IN FACT RUNNING.
- 2.) IF THE FAN IS NOT RUNNING, CHECK THE WIRING (BLACK AND RED) AT THE MODULE FOR A PROPER CONNECTION, REFER TO PROPER SCHEMATIC FOR WIRING INFORMATION
- 3.) IF THE FAN IS RUNNING, FEEL THE COLD PLATE INSIDE THE UNIT. THE COLD PLATE IS LOCATED AT THE TOP OF THE INSIDE OF EACH UNIT, IT IS WHITE IN COLOR AND, IF OPERATING PROPERLY, WILL BE COLD TO THE TOUCH.
- 4.) IF AFTER 15 MINUTES, THE COLD PLATE IS NOT COLD TO THE TOUCH AND THE COMPRESSOR IS CONFIRMED RUNNING/OPERATING, THE UNIT HAS A ISSUE WITH THE REFRIGERANT AND NEEDS TO BE RETURNED TO THE FACTORY FOR REPAIRS.

### **NO COMPRESSOR, NO FAN:**

- 1.) ENSURE THE CONTROL BOARD IS ATTACHED WITH 12-VOLT DC POWER. THE CONTROL BOARD SHOULD BE ILLUMINATED, INDICATING 12-VOLT DC IS ACTIVE
- 2.) SHOULD THE UNIT ALREADY BE INSTALLED, ENSURE THE PROPER 12-VOLT DC IS PRESENT. THE UNIT WILL NOT OPERATE BELOW 9.7 VOLTS AND WILL NOT OPERATE ABOVE 17 VOLTS.
- 3.) VERIFY THE POWER IS ON. IF NOT CHECK THE 12-VOLT DC POWER SUPPLY AND USE A SECONDARY POWER SUPPLY IF NECESSARY FOR TESTING PURPOSES.
- 4.) IF THE POWER IS ON, AND THE COMPRESSOR AND FAN ARE NOT RUNNING, CHECK THE WIRING AT THE MODULE. REFER TO THE PROPER WIRING SCHEMATIC FOR YOUR UNIT.

### **COMPRESSOR OPERATES, NO FAN:**

- 1.) VERIFY THE FAN WIRES (BLACK AND RED WIRES) ARE PROPERLY CONNECTED TO THE ELECTRONIC MODULE AT THE (+) AND "F" TERMINALS
- 2.) VERIFY THE FAN IS NOT OBSTRUCTED WITH A WIRE OR OTHER IMPURITY
- 3.) IF BOTH #1 AND #2 ARE CLEAR, CHANGE THE FAN FOR PROPERLY OPERATION

### **FAN OPERATES, NO COMPRESSOR:**

- 1.) VERIFY PROPER 12- VOLT DC IS APPLIED TO THE UNIT. THE FAN WILL OPERATE BELOW THE MINIMUM 9.7 VOLTS FOR THE COMPRESSOR
- 2.) VERIFY THE COMPRESSOR WIRES ARE CONNECTED TO THE MODULE. THE UNIT COMES PRE-WIRED, BUT SHOULD THE WIRES BECOME REMOVED FOR ANY REASON, THEY SHOULD BE CONNECTED TO THE (+) AND (-) TERMINALS ON THE MODULE. SEE PROPER WIRING SCHEMATIC FOR YOUR UNIT.



# TROUBLESHOOTING

## **FAN OPERATES, NO COMPRESSOR (CONT'D):**

- 3.) IF THE COMPRESSOR STILL DOES NOT OPERATE, PROVIDE A SECONDARY SOURCE OF POWER (POWER SUPPLY BOX, 12-VOLT DC PORTABLE POWER SUPPLY, OR ANY OTHER SOURCE THAT PROVIDES THE CORRECT VOLTAGE RANGE OF POWER) AND CONNECT IT DIRECTLY TO THE (+) AND (-) TERMINALS LOCATED ON THE COMPRESSOR'S MODULE. SIMPLY REMOVE THE (+) AND (-) WIRES ALREADY CONNECTED AND REPLACE THEM WITH THE SECONDARY POWER SOURCE. THIS WILL "JUMP OUT" THE CONTROL BOARD AND PROVIDE POWER DIRECTLY TO THE COMPRESSOR. IF THE COMPRESSOR STARTS, CHECK THE WIRING AT THE CONTROL BOARD. IF THE COMPRESSOR DOES NOT START, REPLACEMENT OF THE MODULE OR COMPRESSOR MAY BE REQUIRED. CONTACT FMMS'S FACTORY FOR ASSISTANCE, PARTS, OR HELP WITH SENDING THE UNIT IN FOR REPAIRS.

## **NO POWER TO CONTROL BOARD/THERMOSTAT:**

- 1.) CHECK THE 10 AMP FUSE LOCATED ON THE BACK OF THE CONTROL BOARD. IF THE FUSE IS BLOWN, REPLACE.
- 2.) IF FUSE CONTINUES TO BLOW AFTER REPLACEMENT, CHECK WIRING FOR PROPER CONNECTION, SHORTS, AND CORROSION. ALSO VERIFY THAT THE 12-VOLT DC POWER SOURCE IS PROVIDING STEADY AND CONSISTENT POWER FREE OF VOLTAGE DROPS/SPIKES. ENSURE WIRING IS PROPERLY SIZED FOR THE DISTANCE FROM THE SOURCE. SEE PROPER WIRING SCHEMATIC FOR YOUR UNIT.
- 3.) IF BOARD SHOWS ZERO TEMPERATURE, CONFIRM T-STAT WIRES ARE CONNECTED TO THE CONTROL BOARD.

# WIRING SCHEMATIC FOR 2020-CURRENT

THIS WIRING COVERS UNITS EQUIPPED WITH A BDI.4, BD35F, AND BD50F BUILT AFTER 2020 AND REPLACED THE MASTERFLUX CASCADE COMPRESSOR

## Wire dimensions DC

Cross section [mm <sup>2</sup> ]	Size AWG [Gauge]	Max. length* 12V operation		Max. length* 24V operation	
		[m]	[ft.]	[m]	[ft.]
2.5	12	2.5	8	5	16
4	12	4	13	8	26
6	10	6	20	12	39
10	8	10	33	20	66

\*Length between battery and electronic unit

## Danfoss/ Secop Module Wiring

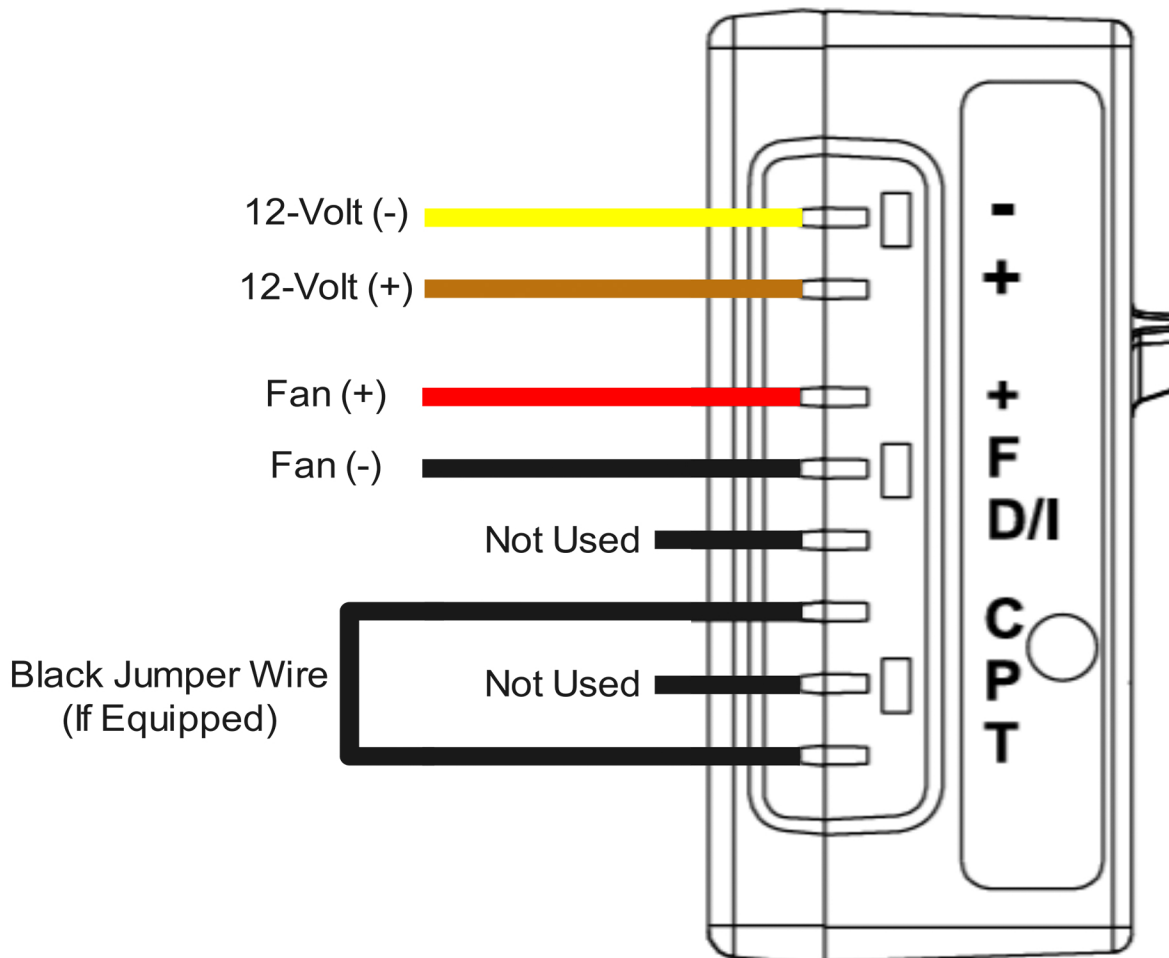

# WIRING SCHEMATIC FOR MASTERFLUX CASCADE COMPRESSOR

## NOTE: FOR UNITS BUILT 09/2015 TO 2020

EACH CONTROL BOARD WILL PERFORM A 3 MINUTE DELAY BEFORE THE COMPRESSOR TURNS BACK ON ONCE THE CABINET HAS REACHED THE SET TEMPERATURE. THIS FEATURE IS NECESSARY FOR THE COMPRESSOR TO FUNCTION

### MODULE:

(FT) FAULT OUTPUT

(UV) UNDER VOLTAGE  
PROTECTION OUTPUT

(SP) SPEED INPUT

(G) GROUND

(+F) FAN OUTPUT POSITIVE

(-F) FAN OUTPUT GROUND

(+B) INPUT POWER POSITIVE

(-B) INPUT POWER GROUND

### WIRES:

**GREEN** = FAULT LIGHT

OPEN = NO WIRE

**BLACK** = RESISTOR CONNECTING TO BLUE

**BLUE** = COMPRESSOR WIRE

THIN **RED** = POSITIVE FAN

THIN **BLACK** = NEGATIVE TO FAN

**BROWN** = INCOMING 12/24V POWER

**YELLOW** = NEGATIVE 12/24V POWER

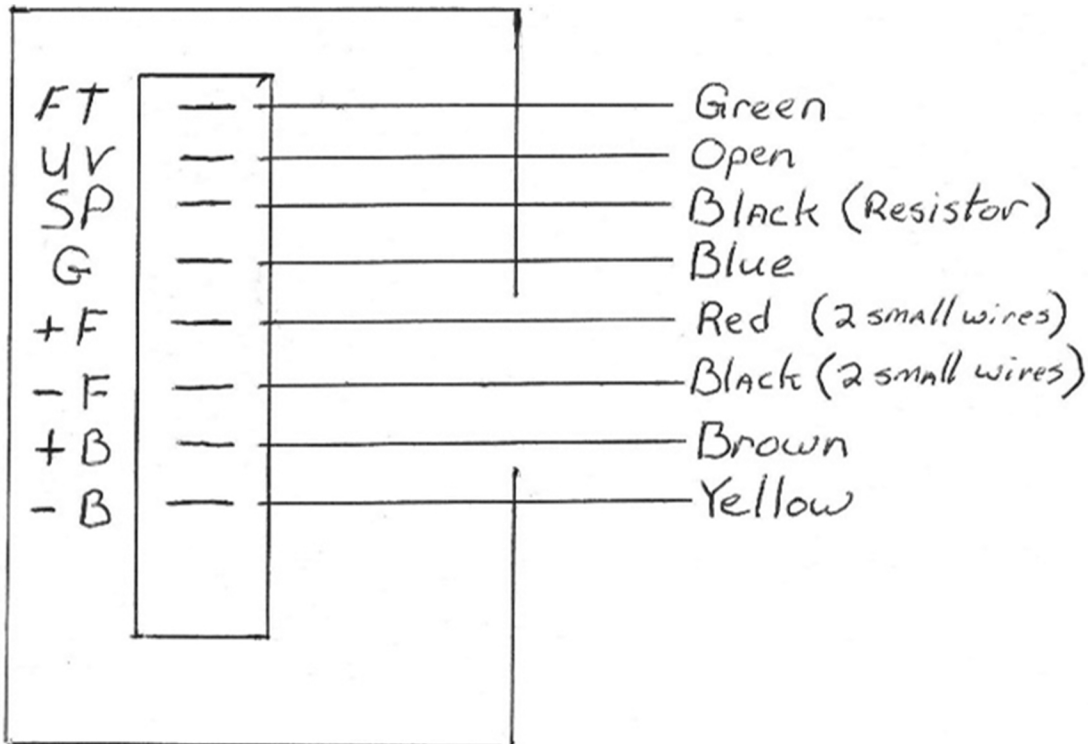

# WIRING SCHEMATIC DANFOSS BD35 AND BD50 ELECTRONIC MODULE

**NOTE: FOR UNITS BUILT BEFORE 09/2015**

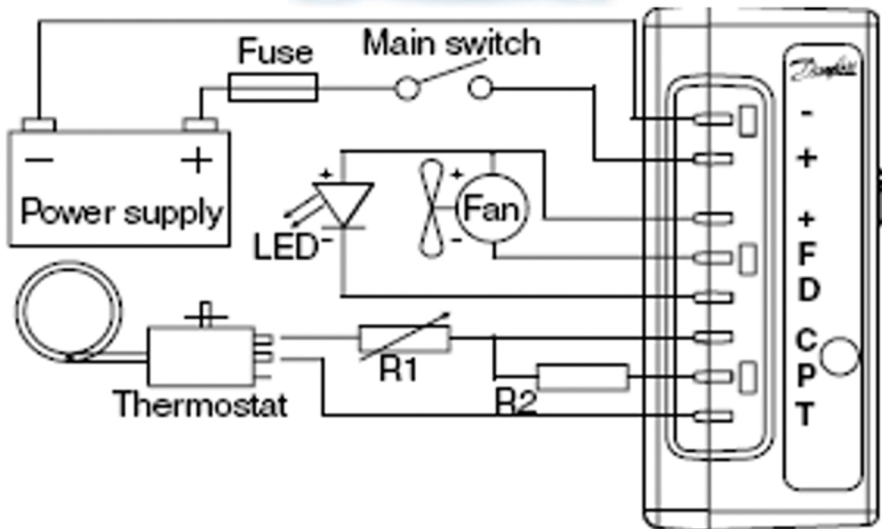

**ELECTRONIC MODULE WIRING DIAGRAM FROM PRE-WIRED MEDI-KOOL™ CONTROL BOARD TO COMPRESSOR MODULE:**

**Wire dimensions**

Size AWG	Cross section mm <sup>2</sup>	Max length* 12V operation		Max length* 24V operation	
		Gauge	ft.	m	ft.
12	2.5	8	2.5	16	5
12	4	13	4	26	8
10	6	19.5	6	39	12
8	10	32.8	10	65.6	20

\*Length between battery and electronic unit

Operational errors shown by LED (optional):

**BD35F / BD50F / BD35K Solar / BD35F Solar**

Number of flashes	Error type
5	<b>Thermal cut-out of electronic unit</b> (If the refrigeration system has been too heavily loaded, or if the ambient temperature is high, the electronic unit will run too hot).
4	<b>Minimum motor speed error</b> (If the refrigeration system is too heavily loaded, the motor cannot maintain minimum speed at approximately 1,850 rpm).
3	<b>Motor start error</b> (The rotor is blocked or the differential pressure in the refrigeration system is too high (>5 bar)).
2	<b>Fan over-current cut-out</b> (The fan loads the electronic unit with more than 1A <sub>peak</sub> ).
1	<b>Battery protection cut-out</b> (The voltage is outside the cut-out setting).

- | MODULE:           | WIRES:  |
|-------------------|---|
| (-) NEGATIVE LEAD | <b>BLACK WIRE</b> (NEGATIVE 12/24V) FROM WHITE TERMINAL BLOCK PRE-WIRED FROM THE MERMAID FACTORY.     |
| (+) POSITIVE LEAD | <b>RED WIRE</b> (INCOMING 12/24V POWER) FROM WHITE TERMINAL BLOCK PRE-WIRED FROM THE MERMAID FACTORY. |
| (+) POSITIVE LEAD | <b>THIN RED WIRE</b> (FAN) + <b>BLUE WIRE</b> PIGGY BACKED  |
| (F) NEGATIVE LEAD | <b>THIN BLACK WIRE</b> (FAN)  |
| (D) FAULT LIGHT   | <b>GREEN WIRE</b> ( <b>BLUE</b> ABOVE IS ALSO FAULT LIGHT)  |
| (C) SPEED CONTROL | <b>BLACK JUMPER WIRE</b> (C-T TERMINAL)   |
| (P) OPEN TERMINAL | NO WIRE   |

**EACH FMMS UNIT ALSO HAS (A) HEATER(S) INSTALLED, THERE ARE TWO RED OR BLACK WIRES EXITING THE CASE NEAR THE INSULATED EVAPORATOR LINE. THESE WIRES OPERATE THE HEATER AND ARE CONNECTED DIRECTLY TO THE MEDI-KOOL CONTROL BOARD**

**WE THANK YOU FOR YOUR BUSINESS AND TRUST THAT YOU WILL HAVE MANY YEARS OF SUCCESSFUL OPERATION WITH YOUR FREEDOM MEDI-KOOL CLIMATE CONTROLLED RX UNITS!**



# FMMS

**FREEDOM MEDICAL &  
MARINE SOLUTIONS**



**2651 PARK WINDSOR DR  
SUITE 203, FORT MYERS  
FL 33901  
(239)-689-5033  
OFFICE@FMMSUSA.COM**

**DBA MERMAID  
MANUFACTURING**

